

THE HYDROSHIELD™ SEALING SYSTEM

MADE WITH AMPS™ AND DUALPAC® TECHNOLOGIES

Prevent Losses, Minimize Costs, and Increase Safety with the Hydroshield Sealing System

AUTOMATE MAINTENANCE TO OPTIMIZE OPERATIONS

What is the Hydroshield Sealing System?

Hydroshield technology is an innovative sealing system for hydro turbines that leverages our AMPS™ and DualPac® technologies, along with remote monitoring and control capabilities, to make hydro turbine maintenance safer, faster, and more efficient.

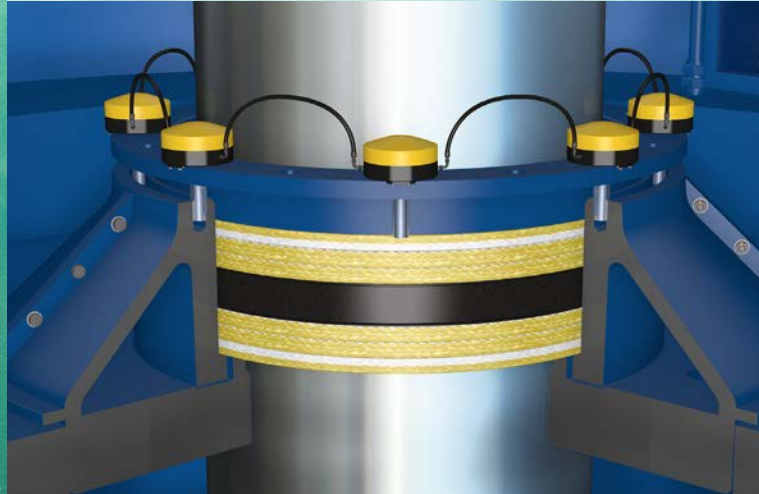

THE BENEFITS OF THE HYDROSHIELD SEALING SYSTEM

Over time, packing loses its volume and must be tightened and repacked regularly, causing excessive leakage and even possible loss of production capabilities. Our proprietary Hydroshield technology minimizes production downtime by automatically providing a uniform and consistent load.

With automatic readjustments using the AMPS actuators, the need for operators working in proximity of rotating equipment is eliminated. The Hydroshield Sealing System lowers equipment maintenance costs and addresses occupational safety concerns.

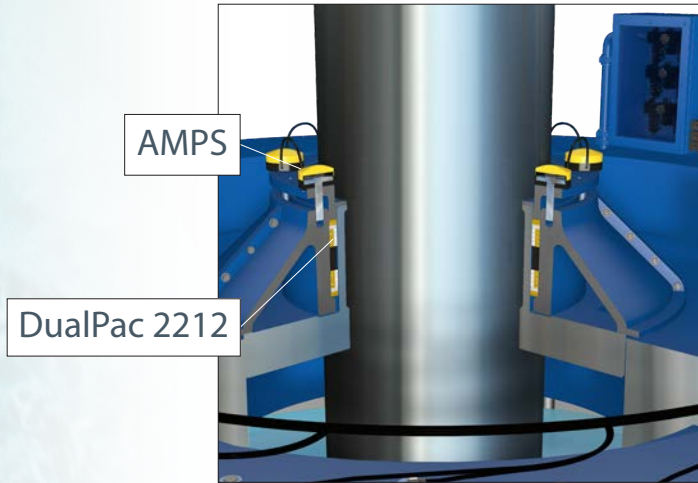

AMPS and DualPac Technology: Improve Packing Life

AMPS technology utilizes a simple, remote loading system to automatically load Mechanical Packing in Rotary Equipment. The Piston Actuator uniformly and consistently loads mechanical packing. DualPac packing incorporates state-of-the-art synthetic fibers with lubricants and blocking agents to provide exceptional performance in a wide range of sealing challenges.

IMPROVING EQUIPMENT EFFICIENCY AND SAFETY SINCE 1884

The Hydroshield Sealing System brings Chesterton's commitment to leveraging technology to improve the efficiency, productivity, and safety of process industry plants. Chesterton is the go-to company for solving the most difficult sealing and equipment reliability challenges.



The Hydroschild Two-Fold System: AMPS and DualPac Technologies

MAXIMIZE PERFORMANCE WITH ACTIVE LOADING THROUGH THE AMPS SYSTEM

The AMPS unit uses Active Loading to maintain a uniform and consistent load to eliminate manual packing adjustments and maximize performance and packing life.

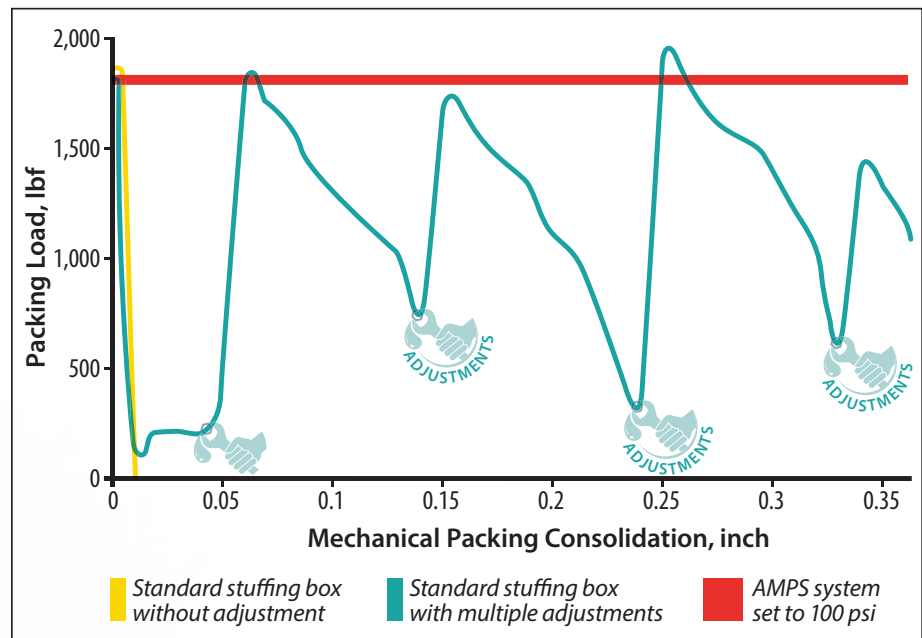

The AMPS System: Automated Gland Loading

The AMPS System is made of two main components that work together with packing to automatically and efficiently seal hydro turbines.

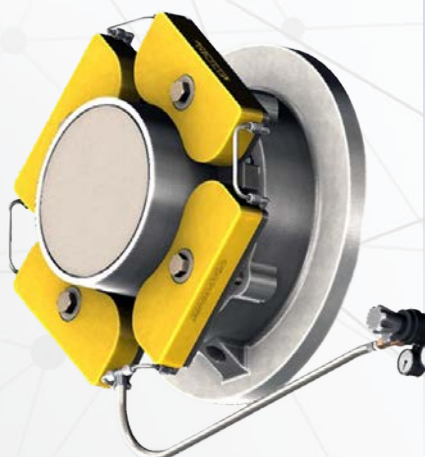

AMPS: Also available in dual piston design as shown in the picture.

AMPS Unit

- Piston actuators
- Single or dual design
- Attaches to existing box glands and bolts
- Provides constant energizing force to packing

Control Unit

- Single point adjustment of pressure regulator
- Mounted remotely at a convenient location
- Compress plant air/gas supply

RESILIENT PACKING WITH MAXIMUM EXTRUSION RESISTANCE DUALPAC PACKING DELIVERS

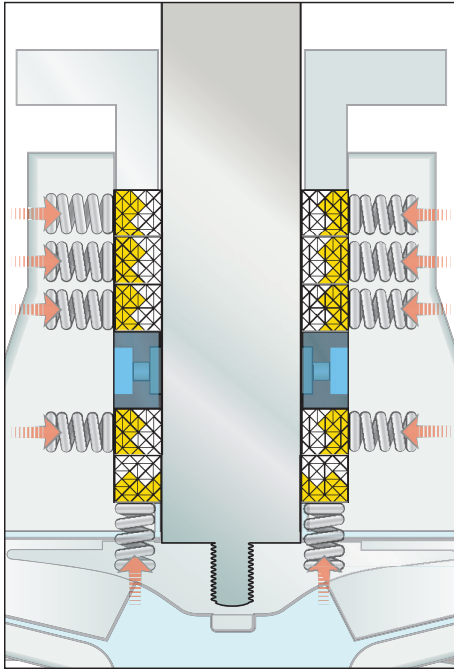

Solids Resistance and Anti-Extrusion

With traditional methods, packing loses volume throughout the operation, requiring manual retightening on a regular basis.

DualPac packing uses two high-performance synthetic fibers to increase resilience and packing life. With these innovative fibers, you can rotate the packing to reduce leakage and volume loss.

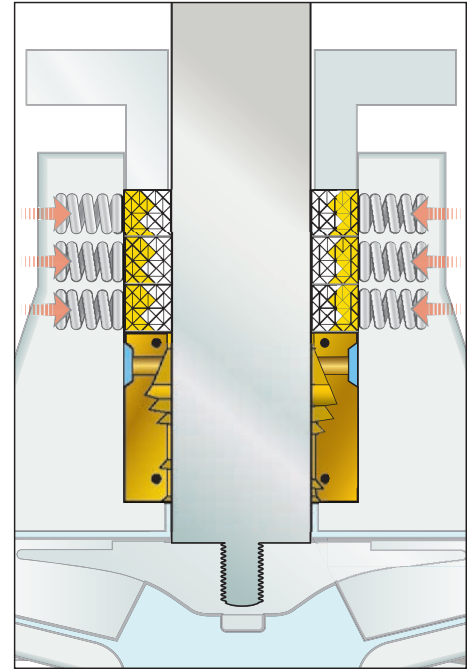

Chesterton DualPac® SuperSet™

DualPac Proprietary Packing Technology

High-Performance DualPac technology is Heat-Resistant, High-Pressure, Non-Staining Packing with Superior Sealing Performance.

DualPac Proprietary Packing Technology

- Superior sealing using proprietary technology
- Configured for maximum extrusion resistance
- Para-aramid fibers provide resiliency
- Meta-aramid provides easy break-in and maintenance
- Efficient load transfer for superior sealing
- Minimum aramid-shaft contact



The Hydroshield Difference:

EASIER INSTALLATION, MORE ADAPTABLE, WITH REMOTE CAPABILITIES

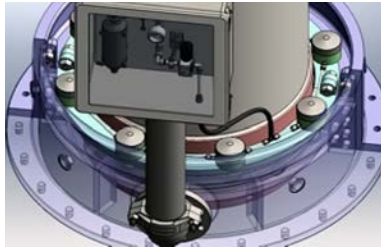

Hydroshield Sealing System's use of Chesterton® proprietary packing technology and Automatic Mechanical Packing System makes the technology more adaptable, reliable, and longer lasting than other sealing options.

	Hydroshield™ Sealing System	Radial Segmented Seals	Axial Seal
SIZE	No limit – Dependent on space available	Typically up to 80"	Typically, 30" split seal up to 36"
PRICE	Most economical	Expensive (~2x Hydroshield Sealing System)	Most expensive (~3x – 5x Hydroshield Sealing System)
PRESSURE RATING	Up to 500 PSIG (Stuffing box)	20 – 40 PSIG	Up to 100 PSIG
ADAPTABILITY	Automatically adjusts (±5%) to system pressure changes. Manual change also possible through regulator	None	None
FLUSH CONDITION	No special filtration system required	Special water filtration (Max particle 25-micron)	Max particle size 30 – 50 micron
SMART CONTROL	Remote control and monitoring (Connect) add-ons available	None	None
INSTALLATION	Easiest to install	Very difficult	Difficult

The Hydroshield System in Action

SEE HOW THE HYDROSHIELD TWO-FOLD SYSTEM HAS MADE AN IMPACT

Help Prevent Costly Equipment Maintenance Costs



Heavy turbine leakage was causing issues.

Challenge

Old Dominion Engineering turbines were operating in conditions where the packing was unable to be tightened, creating leakages, delamination, and corroded metal substrate. These conditions resulted in unnecessary and costly shutdowns.

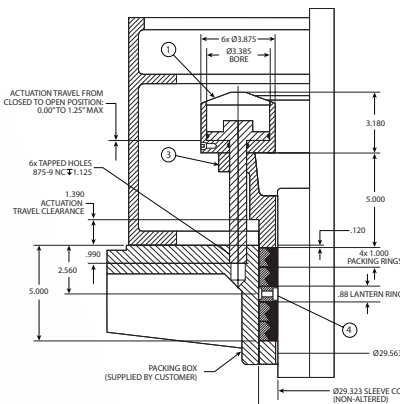

AMPS system with five rings of DualPac 2212 packing.

Solution

Five rings of DualPac® 2212 Severe Slurry Packing were installed along with Chesterton® AMPS™ Technology.

The Chesterton proprietary AMPS (Automated Mechanical Packing System) is a fully autonomous packing system with active loading technology.

This combination greatly reduced maintenance costs and mitigated safety concerns by automatically adjusting packing compression.



AMPS Technology in operation since April 2021.

Results

The system complied with all the technical requirements.

The Hydroshield Sealing System resolved the issue of repeated adjustments by applying the correct compression to the packing, providing reliable and smooth operation.

Costs from excessive leakage were lowered and plant safety increased.

Higher MTBR (Mean Time Between Repair) resulted in significant savings for the company.



Global Solutions, Local Service

Since its founding in 1884, the A.W. Chesterton Company has successfully met the critical needs of its diverse customer base. Today, as always, customers count on Chesterton solutions to increase equipment reliability, optimize energy consumption, and provide local technical support and service wherever they are in the world.

Chesterton's global capabilities include:

- Servicing plants in over 113 countries
- Global manufacturing operations
- More than 500 Service Centers and Sales Offices worldwide
- Over 1200 trained local Service Specialists and Technicians

Visit our website at chesterton.com



Chesterton ISO certificates available on chesterton.com/corporate/iso

AMPS™ and Hydrosield™ are trademarks of A.W. Chesterton Company. Technical data reflects results of laboratory tests and is intended to indicate general characteristics only. A.W. Chesterton Company disclaims all warranties expressed, or implied, including warranties of merchantability and fitness for a particular purpose or use. Liability, if any, is limited to product replacement only. Any images contained herein are for general illustrative or aesthetic purposes only and are not intended to convey any instructional, safety, handling or usage information or advice respecting any product or equipment. Please refer to relevant Safety Data Sheets, Product Data Sheets, and/or Product Labels for safe use, storage, handling, and disposal of products, or consult with your local Chesterton sales representative.

Distributed by:

© 2023 A.W. Chesterton Company.

® Registered trademark owned by A.W. Chesterton Company in USA and other countries, unless otherwise noted.



A.W. Chesterton Company
860 Salem Street
Groveland, MA 01834 USA

Telephone: 781-438-7000
Fax: 978-469-6528
chesterton.com

Form No. EN601373
The Hydrosield Sealing System
Brochure – English
06/23